





**INSTALLATION
INSTRUCTIONS**

PART NUMBER: F541SAL000

DESCRIPTION: MOONROOF AIR DEFLECTOR

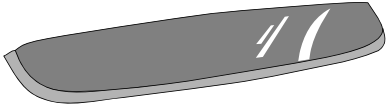
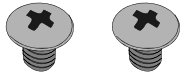
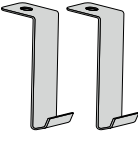
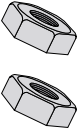
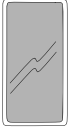
VEHICLE DESCRIPTION: SUBARU OUTBACK

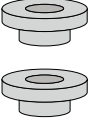
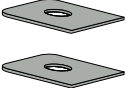
<p>A</p> 	<p>B</p>  <p>1x 2x</p>	<p>C</p>  <p>2x</p>	<p>D</p>  <p>2x</p>	
<p>E</p>  <p>2x</p>	<p>F</p>  <p>1x</p>	<p>G</p>  <p>2x</p>	<p>H</p>  <p>2x</p>	

Tools Required

Phillips head screwdriver

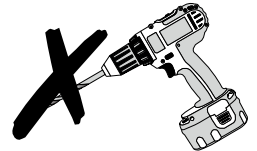
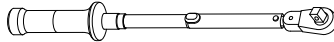

NO POWER TOOLS

Meaning of Characters:

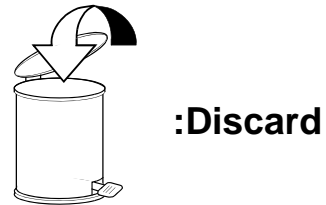
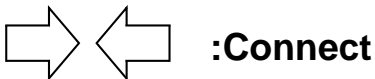
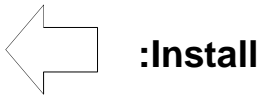
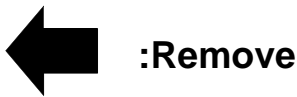

IMPORTANT NOTES

- DO NOT USE SOLVENT BASED CLEANERS ON MOONROOF AIR DEFLECTOR.
- DO NOT USE LOCTITE ON DEFLECTOR ATTACHING SCREWS.
- USE SOAP AND WATER ONLY TO CLEAN MOONROOF AIR DEFLECTOR.

The moonroof air deflector is designed to reduce wind noise when the moonroof is in the opened position. However, in some cases wind noise may be slightly louder with the moonroof in the tilt or closed position.

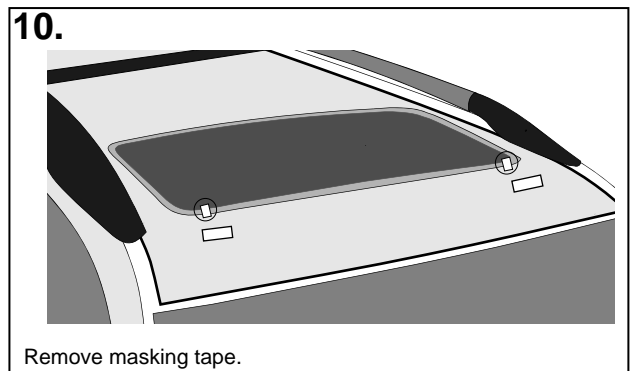
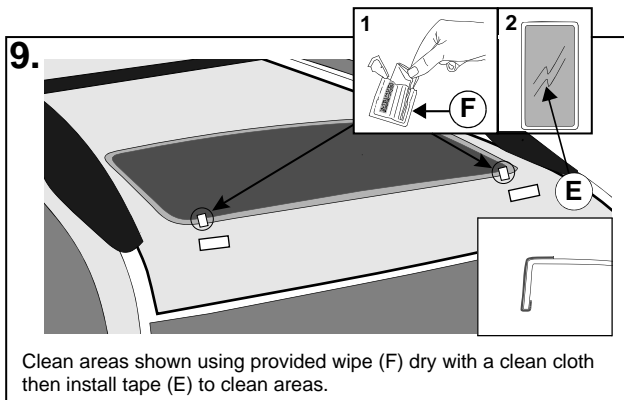
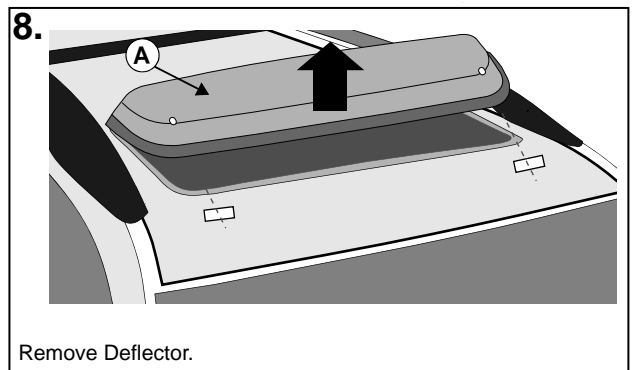
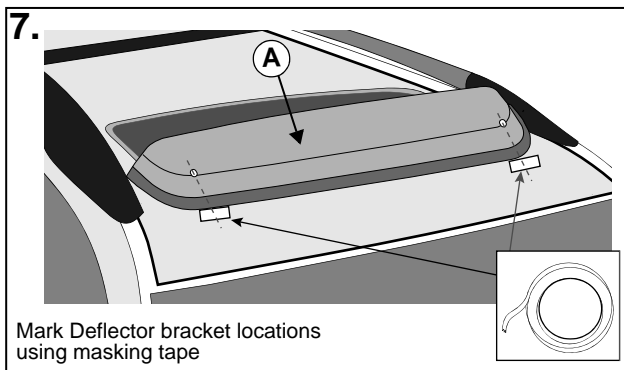
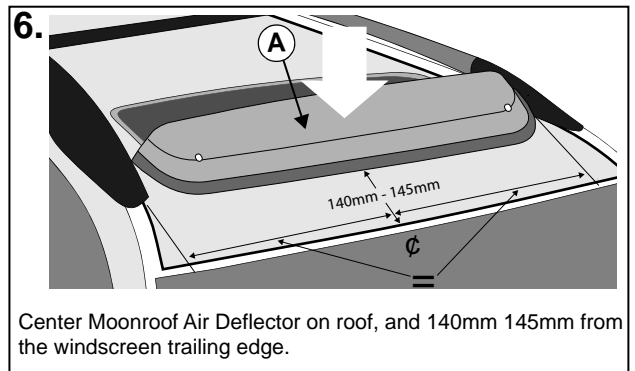
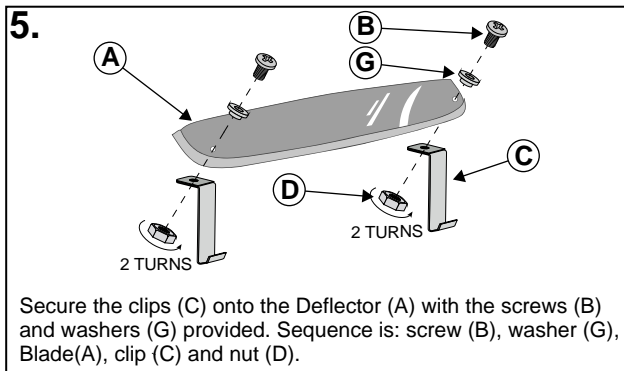
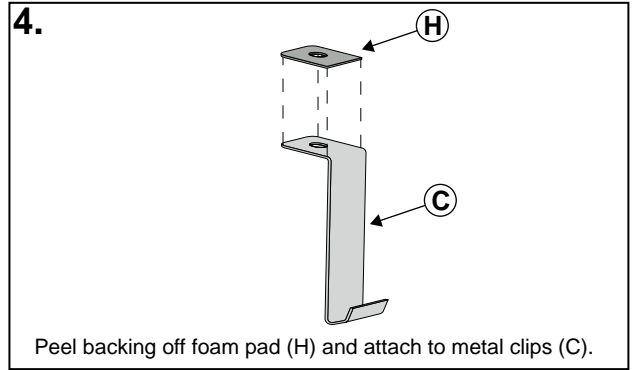
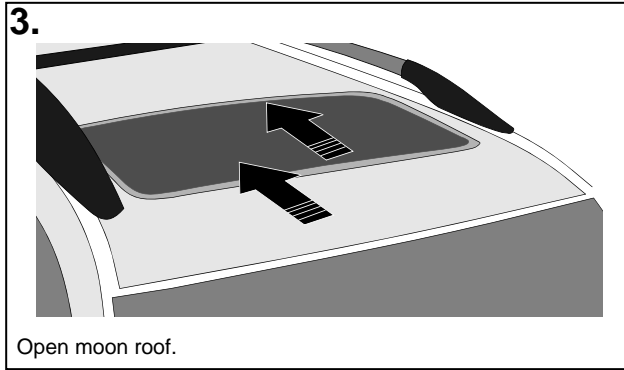
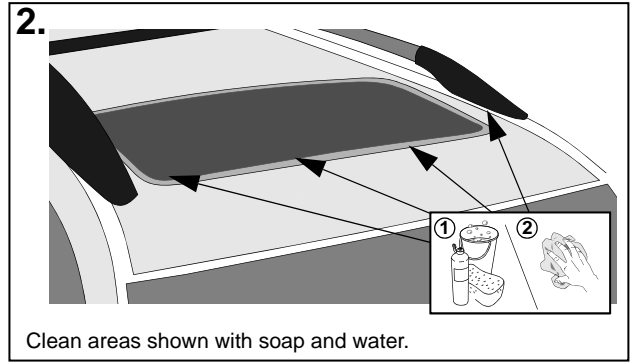
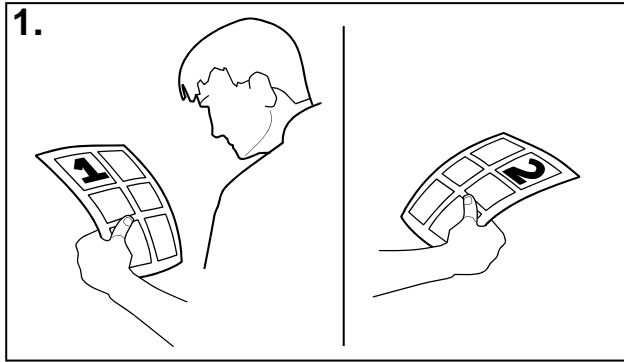

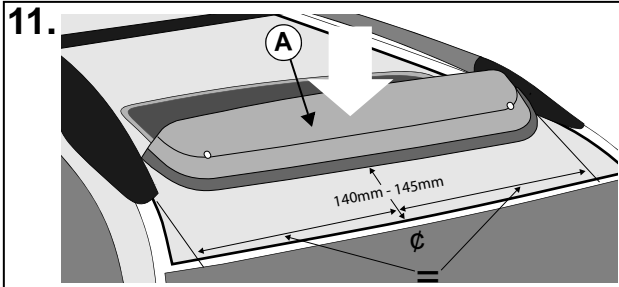

Center Moonroof Air Deflector on roof, and 140mm - 145mm from the windscreen trailing edge.

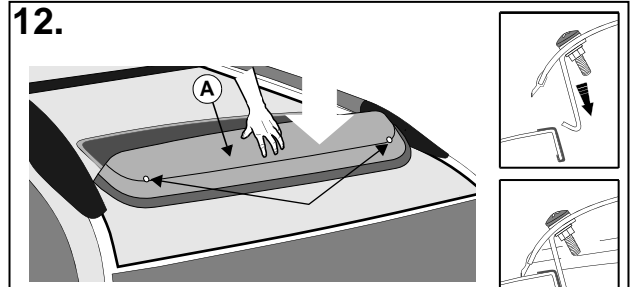

Push down gently on Deflector (A) so clips (C) hook under Moonroof sheet metal flange.

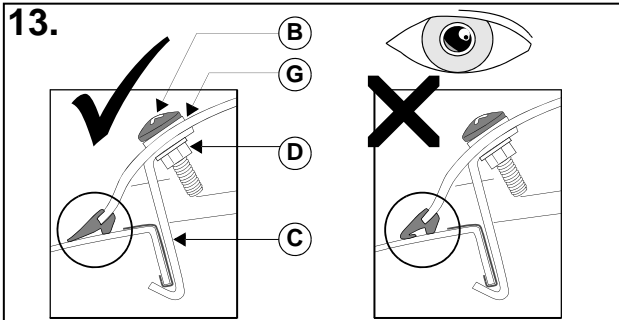

Before tightening, ensure the rubber seal is flat against the roof and not curling under itself.

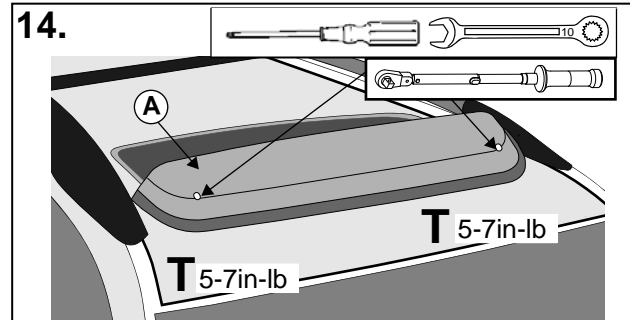

Tighten screws and nuts to secure Deflector to roof.

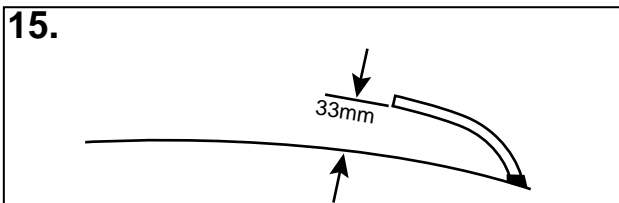

Moonroof Air Deflector should not exceed 33mm above moon roof glass at center. If moon roof Deflector is more than 33mm check for improper installation and ensure screws and nuts are tightened securely.

DO NOT USE solvent based cleaners on Moonroof Air Deflector.
USE soap and water only to clean Moonroof Air Deflector.

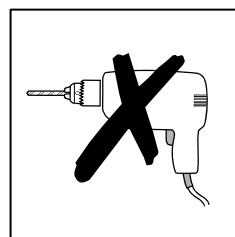





INSTRUCTIONS D'INSTALLATION

NUMÉRO DE PIÈCE : F541SAL000

DESCRIPTION : DÉFLECTEUR D'AIR DE TOIT OUVRANT

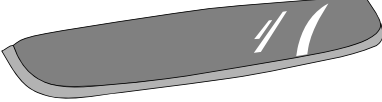
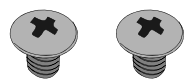
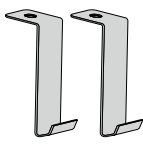
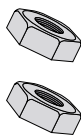
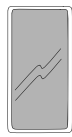
DESCRIPTION DU VÉHICULE : OUTBACK DE SUBARU

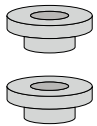
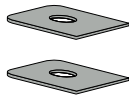
A  1x		B  2x	C  2x	D  2x	
E  2x	F  1x	G  2x	H  2x		

Outils requis

Tournevis Phillips

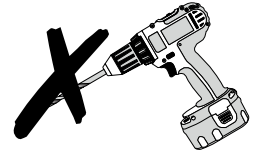
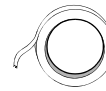
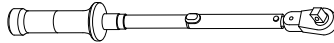

AUCUN OUTIL ÉLECTRIQUE

Signification des symboles :



: Enlever

T

: Couple de serrage

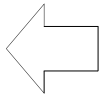

: Poser



: Desserrer



: Déconnecter

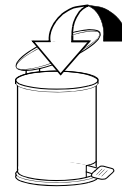

: Jeter

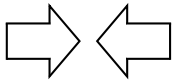

: Connecter

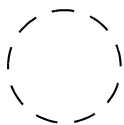

: Emplacement des attaches ou vis

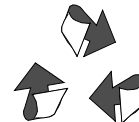

: Réutiliser

REMARQUES IMPORTANTES
 • N'UTILISEZ PAS DE NETTOYANT À SOLVANT SUR LE DÉFLECTEUR D'AIR DU TOIT OUVRANT.
 • N'UTILISEZ PAS DE FREIN FILETS (LOCTITE) SUR LES VIS DU DÉFLECTEUR D'AIR.
 • UTILISEZ UNIQUEMENT DU SAVON ET DE L'EAU POUR NETTOYER LE DÉFLECTEUR D'AIR.

Le déflecteur d'air est conçu pour réduire le bruit de vent quand le toit ouvrant est en position ouverte. Toutefois, dans certains cas, le bruit peut être un peu plus fort si le toit est ouvert en inclinaison ou s'il est fermé.

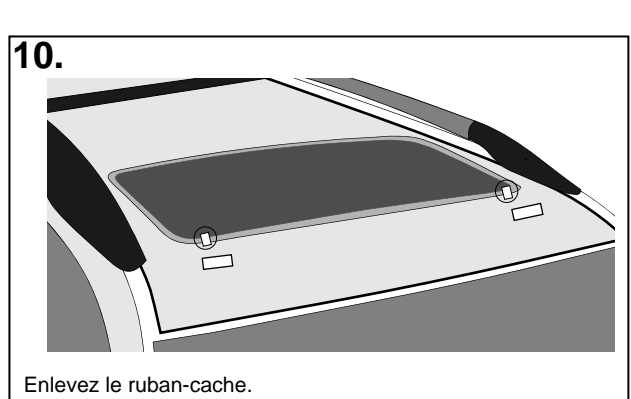
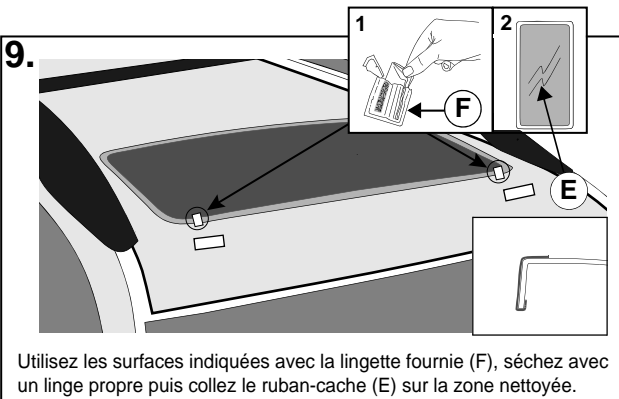
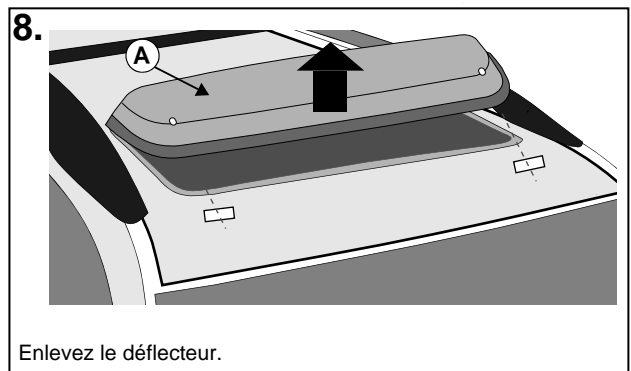
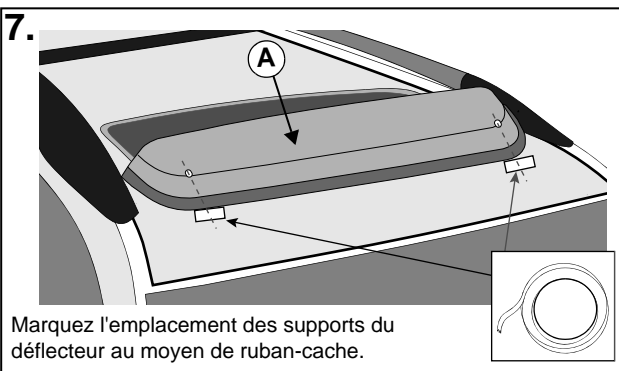
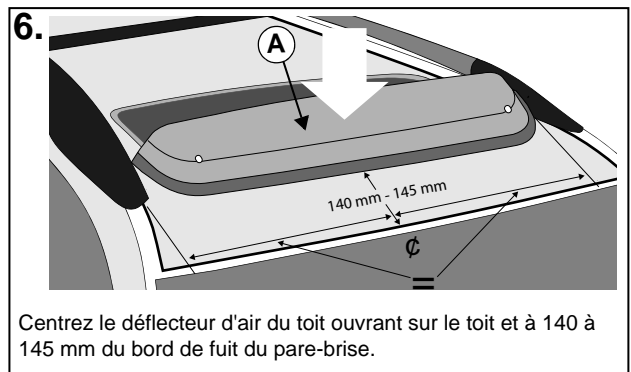
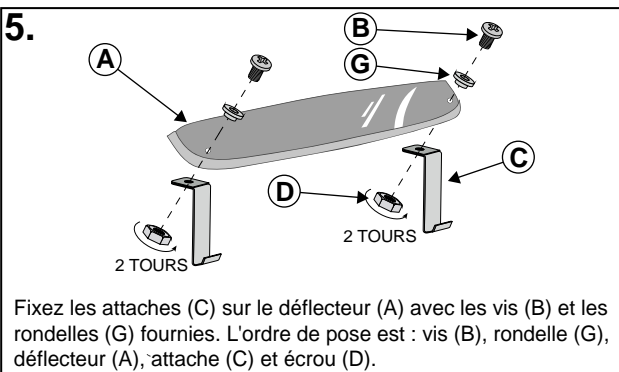
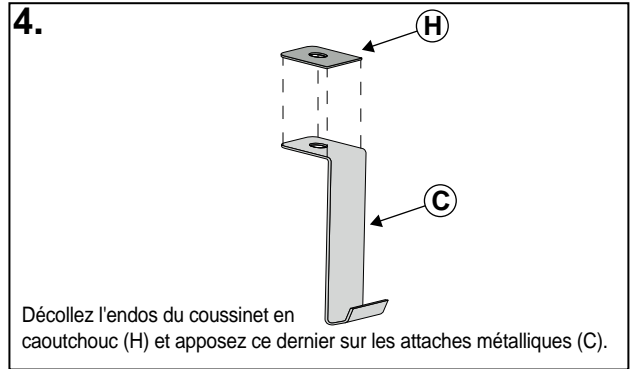
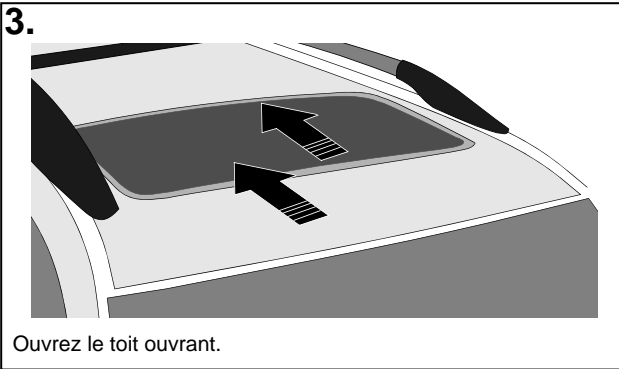
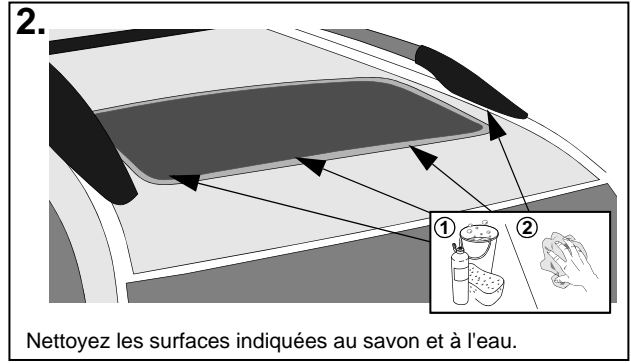
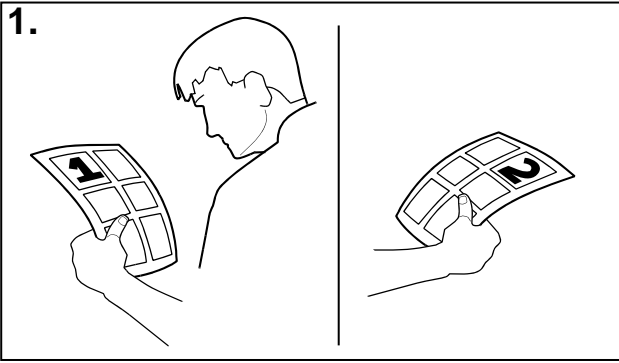

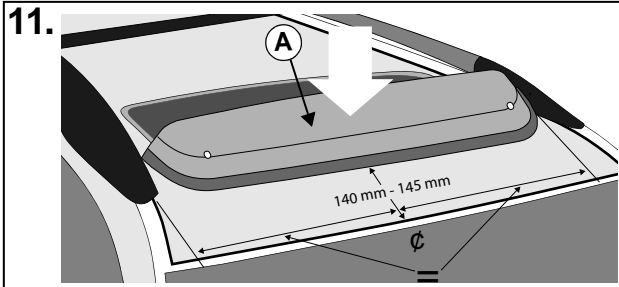

11. Centrez le déflecteur d'air du toit ouvrant sur le toit et à 140 à 145 mm du bord de fuit du pare-brise.

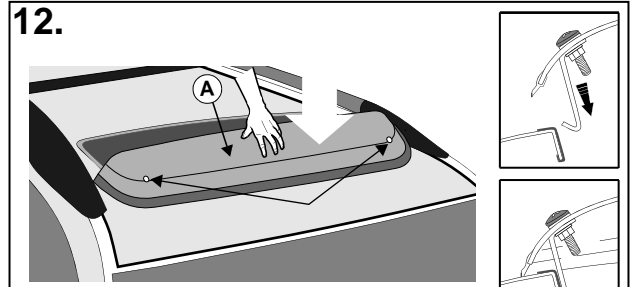

12. Pressez doucement sur le déflecteur (A) pour que les attaches (C) s'accrochent sous le rebord de la tôle du toit ouvrant.

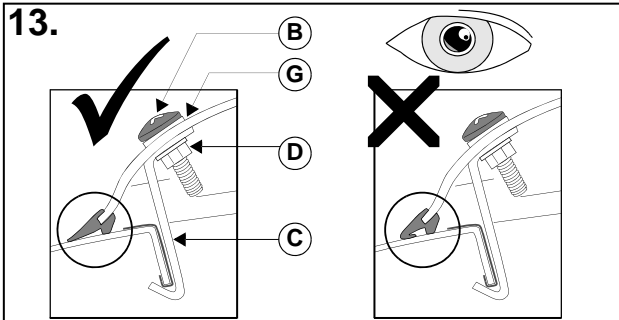

13. Avant de serrer, assurez-vous que le joint en caoutchouc est bien à plat contre le toit et non tordu sur lui-même.

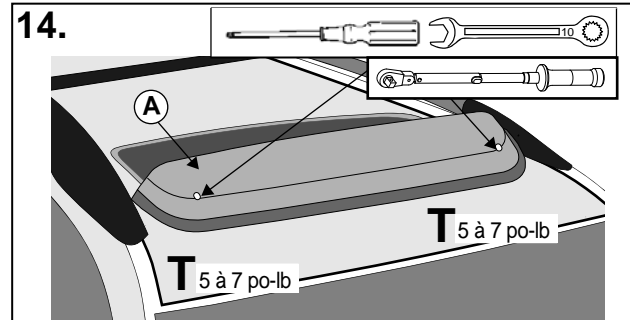

14. Serrez les vis et les écrous de montage du déflecteur au toit.

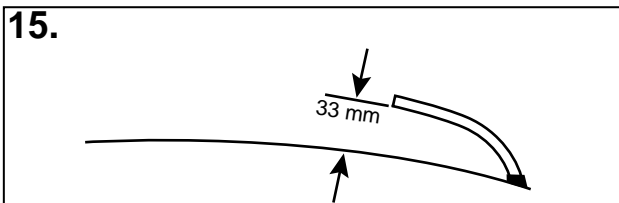

15. Le déflecteur d'air ne doit pas dépasser plus de 33 mm au-dessus de la vitre du toit ouvrant au point milieu. Si le déflecteur dépasse de plus de 33 mm, vérifiez s'il est bien monté et si les vis et les écrous sont solidement serrés.

N'UTILISEZ PAS de nettoyant à solvant sur le déflecteur d'air du toit ouvrant. **UTILISEZ** uniquement du savon et de l'eau pour nettoyer le déflecteur d'air.

